

High Power Red Laser Diode

ADL-63V0ANP

6-2D-LD63-084 Rev.00

★ 635nm 0.5W 25 °C T09 (9mm) PKG

★ Features

- High power
- High brightness
- Long lifetime

★ Applications

- Laser display
- PDT
- Biochemistry
- Military
- Medical/Life and health sciences
- Illumination

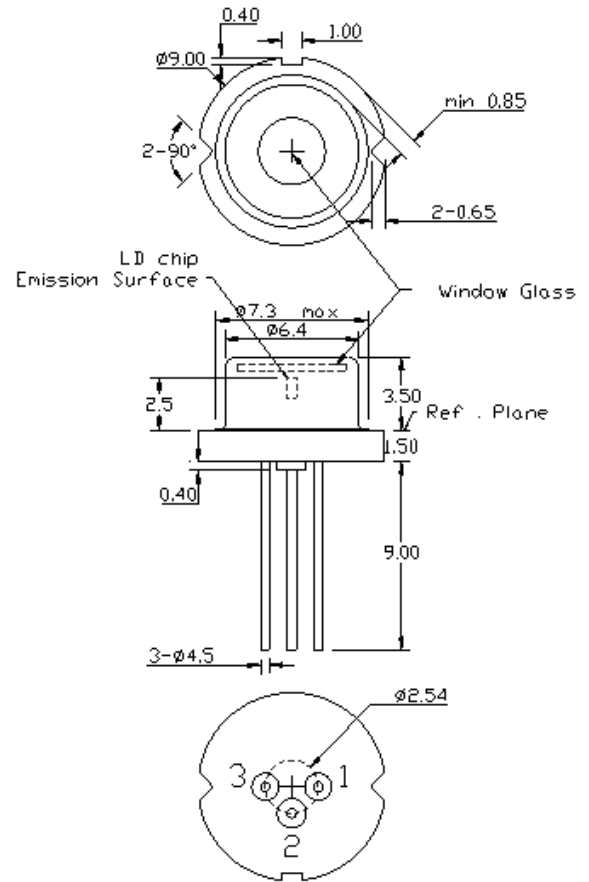

※ Dimensions are in mm.

★ Absolute maximum ratings

Parameter	Symbol	Condition	Rating	Unit
Light output power	P_o	CW	500	mW
Reverse voltage (LD)	V_{RL}	-	2	V
Case temperature	T_c	-	-10~+30	°C
Storage temperature	T_s	-	-40~+85	°C

★ Electrical and optical characteristics ($T_c=25\text{ °C}$)

Parameter	Symbol	Min.	Typ.	Max.	Unit	Conditions
Peak wavelength	λ	632	638	644	nm	$P_o=500\text{mW}$
Polarization			TM			
Threshold current	I_{th}	-	200	300	mA	
Operating current	I_{op}	-	700	900	mA	$P_o=500\text{mW}$
Operating voltage	V_{op}	1.9	2.5	3.0	V	$P_o=500\text{mW}$
Differential efficiency	η	-	1.0	-	mW/mA	
Perpendicular divergence angle	θ_{\perp}	25	36	45	deg	
Perpendicular divergence angle	θ_{\parallel}	-	6	-	deg	

● Precautions

- * Do not operate the device above maximum ratings. Doing so may cause unexpected and permanent damage to the device.
- * Take precautions to avoid electrostatic discharge and/or momentary power spikes. A change in the characteristics of the laser or premature failure may result.
- * Proper heat sinking of the device assures stability and lifetime. Always ensure that maximum operating temperatures are not exceeded.
- * Observing visible or invisible laser beams with the human eye directly, or indirectly, can cause permanent damage. Use a camera to observe the laser.
- * No laser device should be used in any application or situation where life or property is at risk in event of device failure.
- * Specifications are subject to change without notice. Ensure that you have the latest specification by contacting us prior to purchase or use of the product.

* For reference only. Contents above are subject to change without notice.